

A DESCRIPTION OF dPID's NU-ERA¹ TECHNOLOGY SUITE EXECUTIVE SUMMARY

Technology Overview

- The technology consists of:
 - a novel 2D barcode (NU-ERA) representing a 128 bit Identifier that is encrypted, the validity of which can only be truly determined once it is decrypted;
 - an image processing and decryption “machine” that can be resolved down into one silicon chip and would then be fitted to every barcode reader and mobile phone for the purposes of enabling these devices to rapidly read NU-ERA barcodes,
 - a separate decryption chip that could be used for encrypting and decrypting data using AES256 and as such could be useful in the role of High Grade Cryptographic Equipment for mobile computer systems and secure, static or mobile telephones,
 - a registry system for the purposes of allocating large volumes of encrypted Identifiers, to an unlimited Identifier of Customer-Systems, with these Identifiers being guaranteed to be unique and also being a serially sequential allocation for the life of each customer system,
 - a hand-held, portable laser etching system that enables the surface of any object to be marked with this 2D barcode in a fraction of a second, and
 - associated software, including fully developed applications released under the Open Source Software GPL, so that users may easily print NU-ERA barcodes and gain significant productivity benefits from the use of this technology.
- dPID has been granted an Australian Innovation Patent 2012100279 issued 8 May 2012, for the construction and operation of its registry of unique identifiers. It has also been granted Standard Patent 2008247310 issued 30 Aug 2012, covering a system comprised of a reader and a 2D barcode comprised of redundant arrays of dots to represent a binary number (in this instance 128 bits long). These and related patents are pending in China, India, EEU and USA.
- Although the complete suite of technology involves a novel 2D barcode symbology and the means by which it can be read and created, the commercial core of dPID's technology, namely a virtually inexhaustible repository of unique identifiers, can be implemented in the present-day; utilising existing 2D barcodes such as DataMatrix and existing, commercially available barcode readers, such as those marketed by Intermec.
- This technology makes practical and cost-affordable the individual identification of every item of interest within any organisation; allowing disparate enterprises to operate within the same market, safe in the knowledge their identifiers will not be duplicated by their competitors. The NU-ERA barcode is designed to be highly resistant to dirt and damage and typically is only 3.6mm by 4.5 mm in size. The reader circuitry, when resolved down to a single silicon chip will be capable of detecting, reading and decrypting a multitude of barcodes in the field of view of a digital camera at a rate of 200 frames per



¹ NU-ERA stands for Numerically Unique, Encrypted Redundant Array.

second. Using the laser etching system, it is possible to indelibly etch a barcode onto the surface of any material in 1/100th of a second. The range of unique Identifiers is such that a billion, billion Identifiers can be issued per year and the system will not run out of unique Identifiers for 79,228,162,514 years.

5. A demonstrator system developed at the Defence National Supply and Distribution Centre, utilising the unique Identifier registry aspect of this technology suite in combination with DataMatrix barcodes, proved that the effort required to use the dPIID unique identification methodology required almost 60% less labour than using the GS1 system of identification presently being adopted by the Australian Defence Force.

6. The commercial model is to provide every assistance to users so that they can fully avail themselves of the benefits of this technology and to charge them for the Identifiers provided from a globally-based registry system (see www.globalidregistry.org). For this idea to be effective, there must be only one registry; the cost of each Identifier being so small as to make it not viable for other companies to consider competing. It is intended that a significant proportion of this income would be used to develop Open Source Software to the benefit of everyone; particularly the poorer developing nations of this world.

DESCRIPTION

The Concept of an Inexhaustible Source of Unique Identifiers

7. When barcodes were first invented, their purpose was to identify an object either in the generic sense, ie, a type of chewing gum, or individually, ie, an individual person. The first patent was granted to the invention of a barcode in 7 October 1952. It was US Patent 2,612,994. Since that time there have been many types of barcode developed. Many of them have been copyrighted or have some other form of restriction on their use. Intermec, a company in Everett, Washington State, on the West Coast of the USA, in 1972 invented the “Interleaved 2 of 5” symbology as a standard for marking cardboard boxes in supermarkets. In 1974, Intermec invented Code 39, the most widely used alphanumeric barcode symbology in the world. Code 3 of 9 as it came to be called, was exceptional because Intermec made the use of it free of licence. This ensured its popularity.

8. As mentioned with 2 of 5, in some instances, barcodes were invented to cover a particular type of inventory item. The consequence of this was that anyone, wishing to achieve some level of standardisation, was faced with two issues. One involved the type of barcode, the other involved the number range used for that barcode to prevent the same code being used by two suppliers for different articles.

9. Over time, in every advanced industrialised nation, there has formed some organisation seeking to standardise the convention for product identification so that there could be free interaction between suppliers, sellers and consumers² without Identifiers being confused for differing products. Product numbering standards evolved until, somewhere around the year 2000, there was formed a global consortium called GS1, Its aim was that of providing a global standard for all product marking. Unfortunately GS1 was, and still is, hobbled by history and by conventional thinking; driven, no doubt, by commercial realities. No one, up to the advent of NU-ERA, had developed a complete system of bar coding that includes a novel barcode symbology, reader, barcode marker and a unique Identifier registry comprised of Identifiers that cannot be synthesised.

10. The GS1 system has, in its development, aimed to accommodate a wide range of barcode symbologies. In attempting this, it segmented Identifiers in line with the systems it sought to incorporate into its standard, the predominant ones being:

- a. the Universal Product Code (UPC),
- b. the European Article Number (EAN), and
- c. the Uniform Code Council's (UCC) assignment of ID's to manufacturers.

2 The first barcode point of sale supermarket system in Australia was in Queanbeyan at Cannon's Food Barn.

11. At the core of the GS1 system is the Global Trade Item Number (GTIN). This is an identifier for trade items developed by GS1 (comprising the former EAN International and Uniform Code Council). The NU-ERA system, because it does not carry the baggage of history, only has one length and that is 128 bits. This happens to be the largest (reasonable) key one can have in a readily available database engine at the time of writing; namely PostgreSQL. The GS1 system, results in a unique identifier that may be comprised of a string of alphanumeric characters of differing lengths. Being of variable length, the GS1 identifier cannot be used as a primary key in a database. Instead the GS1 identifier has to be an indexed variable. This severely degrades database performance when dealing with large databases. Additionally because of its complexity, the GS1 system of identification is daunting and confusing, especially to the new-comer. Here are some examples of the inherent complexity of GS1 as a consequence of its attempt to encapsulate a wide variety of extant marking systems³:

- a. The EAN-8 code is an eight-digit barcode used usually for very small articles, such as chewing gum, where fitting a larger code onto the item would be difficult. When used in connection with the GS1 convention, the EAN-8 numbering structure is:
 - (1) Indicator digit, used for GTIN-14, "0" to "8" indicates a packaging level and "9" a variable measure item. There is however, no worldwide consensus on which number indicates which packaging level and in some countries (Germany) a leading zero is used independently from item hierarchy.
 - (2) GS1 Company Prefix.
 - (3) Item (product or service) reference number. This part of the numbering structure is allocated by the user company. Each different type of trade item is allocated a different number and, for ease of administration, it is recommended that companies do this sequentially (001, 002, 003, etc.).
 - (4) And a check digit, the last one, which follows a standard GS1 algorithm.
- b. All books and serial publications sold internationally (including those in U.S. stores) have Global Trade Item Number (GTIN-13) codes. The book codes are either constructed by prefixing the old ISBN 10 number with 978, and recalculating the trailing check digit, or from 1 January 2007 issued as thirteen digits starting with 978 (eventually 979 as the 978 ranges are used up).

12. **NU-ERA is Simple yet powerful.** From the beginning NU-ERA's design principle has been simple and pure. It is based on a unique, patented barcode symbology that represents a unique, encrypted Identifier drawn from a registry with a unique, uncomplicated method of Identifier allocation and administration. The unique Identifier issued by the registry is then used by a client-system to point to a particular database record. As such, this Identifier can represent anything the client-system wishes it to; including a GS1 number, an Australian Product Number, an individual sheet of paper in a document management system, a person, an individual piece of fruit, etc, etc. The NU-ERA Identifier is thus a super-number sitting above all other previous standards; including GS1. NU-ERA is based on the fact that modern technology has now made it practical to access databases no matter where in the world the user may be. The database can either be situated locally, ie, on a barcode reader, or it can be located somewhere on a highly complex and feature-rich network such as the Internet. Of interest, barcode readers are now commonly equipped with sufficient memory to hold a list of many millions of items. (dPID has developed software algorithms that allow an item to be found in far less than a second in such a list.) Once a user has access to a database record, the amount of information this unique number can point to is virtually infinite.

13. **NU-ERA is low-cost but flexible.** The simplicity of the NU-ERA system is such that it requires minimal clerical effort and hence it is extremely cheap to label items. On the other hand, GS1 is potentially quite expensive; especially if the business desiring Identifiers from GS1 is a small operator.

3 Source Wikipedia, July 2010

On the GS1 web-page, for example, it is typical for a user to buy five Identifiers at a time. In the NU-ERA system, users can buy millions or billions of Identifiers at a time for very little outlay. In the GS1 system it is necessary users become a member of the consortium and this can involve substantial fees. In the NU-ERA system it is not necessary to become a member. Anyone can register a client-system and be issued Identifiers. The NU-ERA Identifier is 128 bits long of which 96 bits is the “payload”. One thousand, million, billion unique encrypted Identifiers can be issued per year and the registry will not run out of unique Identifiers for 79,228,162,514 years!

Tagging Objects is simpler hence cost of implementation is far less

14. Anyone who has had experience with stores management would appreciate there are broadly three types of stores:

- a. those that must be accounted for individually because of their cost or importance,
- b. those that must be tracked rigorously because they have a shelf-life and their sale to customers if out of date, or somehow contaminated, could have very serious consequences to the business, and
- c. those that are expense items of low value not having the requirements of the other two types listed above.

15. Types a and b are where the money and effort is expended when managing stores. In both instances, individual identification of each item is the surest way of establishing proper control. The problem is the expense of achieving this level of control. As mentioned previously, to achieve individual identification using the GS1 system requires stores personnel have a manufacturer's product number of some description (including, for example a NATO Stock Number - NSN) and then append to that product number a serially allocated number. This means stores custodians must, when creating a label for an item not yet labelled, know the manufacturer's product number or be able to gain access to it, or, in the extreme case, safely generate their own where the item cannot be conclusively identified. Next, they must one can go around their stores facility with:

- a. tags that have been specifically printed for a particular item or a particular type of item, or
- b. have at their disposal a printer such that they can print the barcode onto a tag, representing an individual (unique) identifier for each tagging operation.

16. Any solution that involves the tag carrying on it the name of the item, and a specific numbering hierarchy, as is the case with GS1, forces stores personnel to adopt one of the above approaches. In the case of having preprinted tags and labels, the type of attachment to be used has to be known before the printing of the tag or label. In the real world, when handling a vast array of general stores, this can be impractical. Stores personnel are therefore forced to take a printer into the stores cell and print labels or tags on an “as required basis”. This is expensive in materials and time. Further, if the approach used is to pre-print the labels or tags, there will be considerable time lost whilst stores personnel search through bundles of pre-printed tags or labels looking for the one meant for a particular item. On the other hand, the dPID approach is to simply use tags and labels, each of which has an Identifier on it that is guaranteed to be unique. All that is required is to attach the tag to the item and then find the item, already in the inventory database on a reader, to link it to the unique identifier represented by the barcode on the tag. [Comparative tests indicate this latter approach, using the NU-ERA system of individual identification, can be executed in less than 50% of the time taken to tag items with individual Identifiers derived using the GS1 system.](#)

17. As mentioned, a barcode reader can now typically hold the details of millions of items in memory. dPID's software allows the item to be found in that list in far less than a second by typing as few as three characters making up the item's identifier. Once found, the reader scans the barcode on the tag that has been affixed to the item and from that time onwards, the item's record in the database is linked to the unique Identifier represented by the barcode. The reader then opportunistically communicates the details back to a central database in near to real time. This is a much simpler method and can in many processes,

such as stock taking be made to be automatic. Additionally, when one comes across an article that cannot be easily classified (as has to be the case in the GS1 system where the article effectively is issued a manufacturer's part number or a NATO stock number), it is possible to simply link the unique identifier on the tag to whatever is shown in the inventory listing on the reader. From that time onwards the article can be uniquely tracked within the organisation.

The 2D Barcode Symbology

18. **Summary.** The 2D NU-ERA barcode is typically 4.5mm by 3.6 mm in size and consists of:

- a. 1, 4 or 9 arrays, depending on the application (with multiple arrays being identical);
- b. each array being comprised of 15 dots across and 12 dots down;
- c. these arrays are arranged 3 across and 3 down; presenting a total of 45 dots across and 36 dots down, a total of 1,620 dots in all; and
- d. within an array there are 20 clusters, each cluster being comprised of 9 dots arranged 3 dots across and 3 dots down with the dots complying to a rule that there cannot be three dots of the same colour in either the horizontal or vertical direction within any cluster.

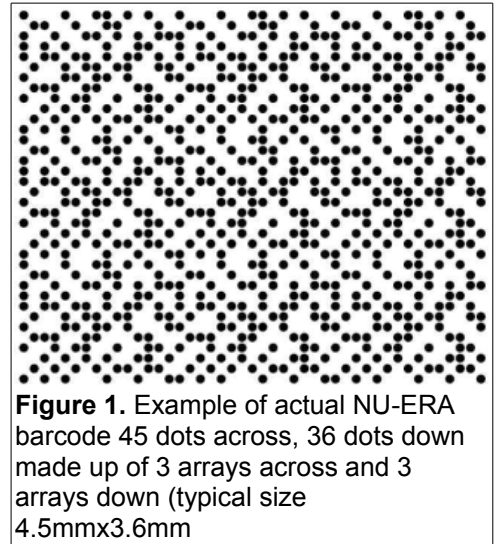

19. This barcode represents a 128 bit Identifier of which 96 bits constitutes the “payload”. The other 32 bits are used for error checking.

20. Per Figure 1, this barcode consists of a pattern of 1,620 dots. The dots in this example may either be black or white; the white dots being invisible against the white background of the barcode.

21. Per Figure 2, these 1,620 dots actually comprise 9 identical arrays, each array having 180 dots.

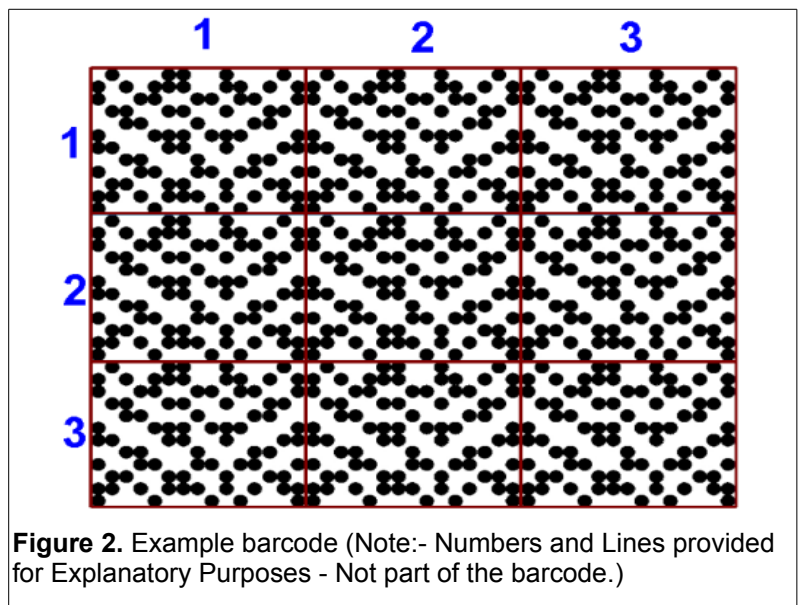

22. Per Figure 3, an array is made up of 20 clusters, each cluster being comprised of 9 dots in an array 3 dots across and 3 dots down. The clusters are arranged 5 across and 4 down as shown.

23. Each cluster represents a number ranging from 0 to 99 and conforms to the rule that there cannot be three dots of the same colour, either in the horizontal or the vertical direction within a cluster.

24. The barcode design purposely only uses dots. It does this for two reasons:

- a. It is possible to make a smaller dot with a low resolution printing or etching device than it is to make a square or rectangle. This means that a barcode comprised of dots can be made smaller with lower grade/cheaper machinery.
- b. By having dots, it is possible to greatly simplify a laser-etching system such that it becomes affordable by small business. Being so, it will make feasible the aspiration to make this technology ubiquitous throughout industry around the world. Laser-etching, as will be described later in this paper, is seen as being a key means of creating the NU-ERA barcode on most objects.

25. The value represented by the barcode is encrypted utilising a well known Open Source Software algorithm. This prevents persons or organisations from generating their own set of valid Identifiers. Instead, they must obtain their Identifiers from a central registry. This ensures that all Identifiers being represented by the NU-ERA barcode are unique.

26. Table 1 provides the complete list of transport code symbols used to represent numerical values from 0 to 99. For example, in the case of black dots against a white background, where black dots indicate binary one (1) and white dots indicate binary zero (0), the number decimal zero (0) is represented by:

- a. one black dot on the left of the top row followed by two white dots,
- b. one black dot on the left of the second row followed by two white dots, and
- c. one white dot on the left of the third row followed by two black dots.

27. Note that in all cases, three dots of the same colour cannot occur in the horizontal or vertical direction within each cluster.

28. The barcode represents a very large binary Identifier that has been encrypted and, combined with the Digital Image Processing functions

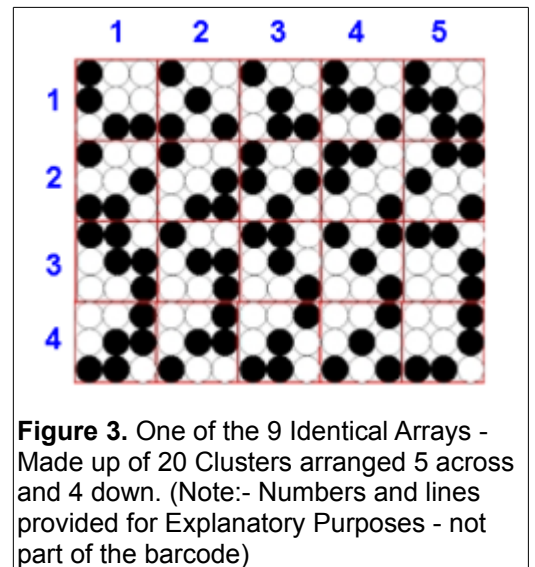

Figure 3. One of the 9 Identical Arrays - Made up of 20 Clusters arranged 5 across and 4 down. (Note:- Numbers and lines provided for Explanatory Purposes - not part of the barcode)

Decimal Value	0	1	2	3	4	5	6	7	8	9
1 st Row	100	100	100	100	100	100	100	100	100	100
2 nd Row	100	010	010	110	110	001	001	101	101	011
3 rd Row	011	101	011	001	011	110	011	010	011	100
Decimal Value	10	11	12	13	14	15	16	17	18	19
1 st Row	100	100	100	100	100	100	010	010	010	010
2 nd Row	011	011	011	011	011	100	100	100	010	110
3 rd Row	010	110	001	101	011	001	101	011	101	001
Decimal Value	20	21	22	23	24	25	26	27	28	29
1 st Row	010	010	010	100	100	010	010	010	010	010
2 nd Row	110	001	001	001	101	101	101	101	101	101
3 rd Row	101	100	110	101	100	010	110	001	101	011
Decimal Value	30	31	32	33	34	35	36	37	38	39
1 st Row	010	010	110	110	110	110	110	110	110	110
2 nd Row	011	011	100	100	010	010	110	001	001	001
3 rd Row	100	101	001	011	001	101	001	100	010	110
Decimal Value	40	41	42	43	44	45	46	47	48	49
1 st Row	110	110	110	110	110	110	110	110	110	110
2 nd Row	001	001	001	101	101	101	011	011	011	100
3 rd Row	001	101	011	010	001	011	100	001	101	010
Decimal Value	50	51	52	53	54	55	56	57	58	59
1 st Row	001	001	001	001	001	001	001	001	001	001
2 nd Row	100	100	010	010	010	110	110	110	110	110
3 rd Row	110	011	100	110	101	100	010	110	001	101
Decimal Value	60	61	62	63	64	65	66	67	68	69
1 st Row	001	001	001	001	001	001	101	101	101	101
2 nd Row	110	001	101	101	011	011	100	100	010	010
3 rd Row	011	110	010	110	100	110	010	011	100	010
Decimal Value	70	71	72	73	74	75	76	77	78	79
1 st Row	101	101	101	101	101	101	101	101	101	101
2 nd Row	010	010	010	010	110	110	110	001	001	101
3 rd Row	110	001	101	011	010	001	011	010	110	010
Decimal Value	80	81	82	83	84	85	86	87	88	89
1 st Row	101	101	101	011	011	011	011	011	011	011
2 nd Row	011	011	011	100	100	100	100	100	100	010
3 rd Row	100	010	110	100	010	110	001	101	011	100
Decimal Value	90	91	92	93	94	95	96	97	98	99
1 st Row	011	011	011	011	011	011	011	011	011	011
2 nd Row	010	110	110	110	001	001	101	101	101	011
3 rd Row	101	100	001	101	100	110	100	010	110	100

Table 1. Transport Codes comprised of Clusters representing numerical decimal values

described hereunder, will provide reliable recovery of the barcode's value:

- a. regardless of the orientation of the barcode to the reader;
- b. whether the dots are white/light-coloured on a black/dark-coloured background or black/dark-coloured on a white/light-coloured background; and
- c. without the need for the barcode's pattern to incorporate any form of fiducial mark.

29. Resistance to Dirt and Damage.

- a. FIG 4 provides an example of an actual NU-ERA barcode that has been deliberately damaged. The dots may be a light colour against a dark background or vice-versa. As per FIG 2, the NU-ERA barcode consists of 9 identical arrays. When being read by the reader, the 9 identical arrays are, in a virtual sense, overlaid, one on top of the other. Where a dot has been damaged by abrasion or by dirt in one array, the other 8 dots belonging to the other 8 redundant arrays “win out” and the reader judges that a dot really does exist in that position. This level of redundancy has been found to provide significant resistance against damage and dirt. Theoretically, 8/9ths of the barcode may be randomly damaged and the barcode can still be read.

b. By way of contrast, FIG 5 is a barcode that utilises a popular 2D barcode technology called DataMatrix and which has been defaced by a pen-stroke. This barcode is no longer readable by most barcode readers.

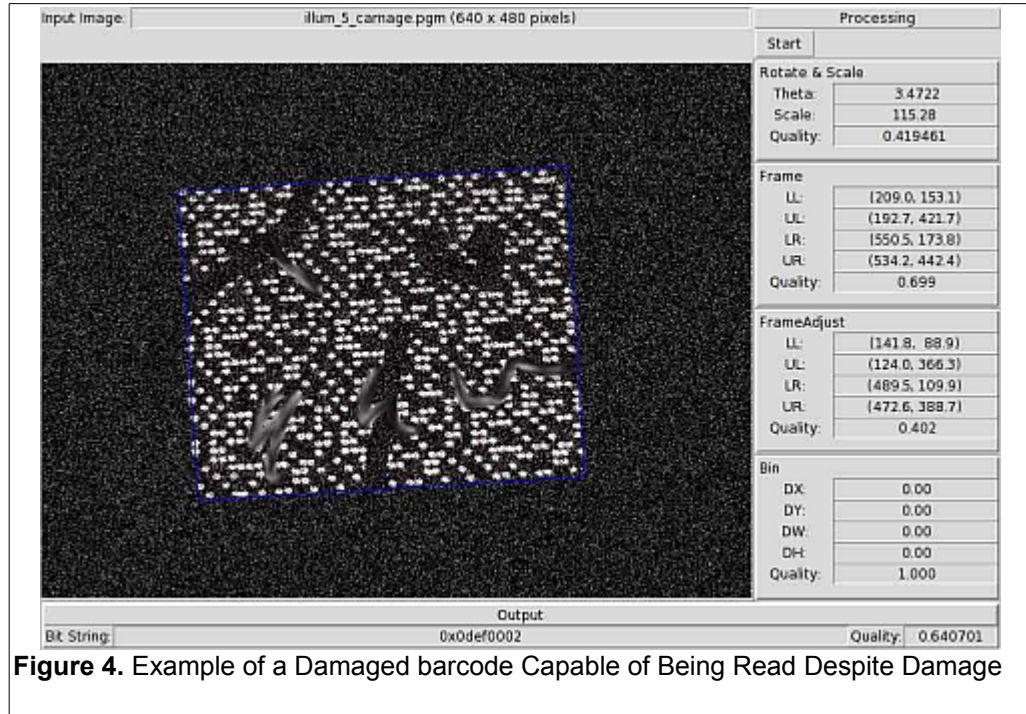

Figure 4. Example of a Damaged barcode Capable of Being Read Despite Damage

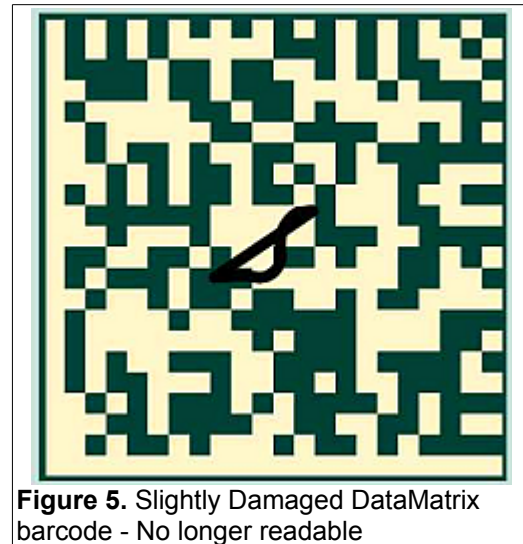

Figure 5. Slightly Damaged DataMatrix barcode - No longer readable

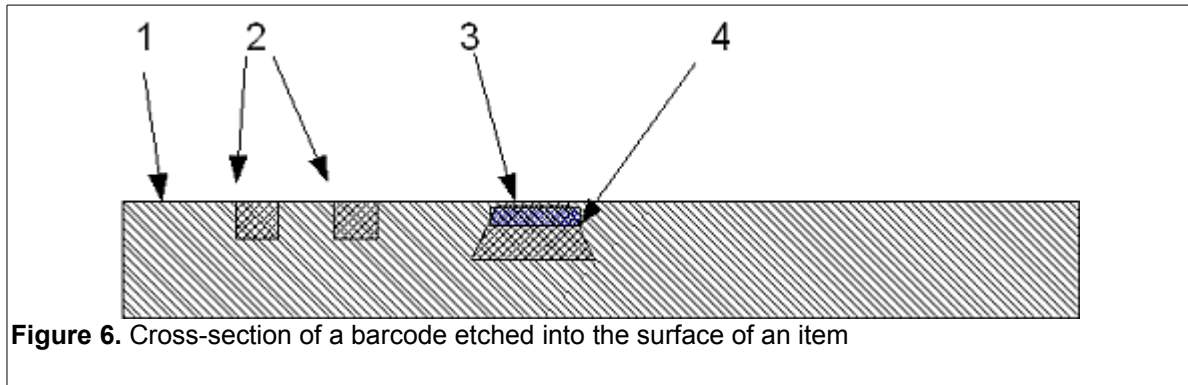

Figure 6. Cross-section of a barcode etched into the surface of an item

30. **Filling Etching with Paint, Ink and/or Glue.** FIG 6 provides a cross-section of a “tag” that consists of a NU-ERA barcode etched into the surface of an item (1). The etching can either take the form of a divot with vertical sides (2) or it can be undercut (4) for the purposes of making sure the ink or glue used to fill the divot cannot come out through shock, flexing and vibration. In “exotic” designs, the filling may be multi-layered. One layer may be an interface layer to provide adhesion. The second layer may be a “binder” that holds a fluorescent compound. The third layer may be a protective layer of a wear resistant substance such as urethane. By filling the etching with a substance, the surface of the object is flat and so is not vulnerable to “snagging” and damage by sharp objects rubbing over the surface. The etching cannot fill with dirt and so by wiping the surface with a rag, the fluorescent compound or white paint is exposed to the reader. This makes the etching highly resistant to dirt and physical damage.

31. **Aid to Robotics – Accurate Determination of the Orientation of Barcodes.** The method used by the reader's logic to orientate a barcode enables the reader to accurately determine the angle in space at which the barcode has been presented. This feature could be useful in the case of robotics, associated with assembly and various industrial processes, where determining the position and placement of an article has always been problematic.

The Reader

32. Figure 7 provides a block diagram describing a generic reader. dPID has concentrated on the “Decryptor & Image Processor”; leaving the other components, such as the camera and camera optics, to companies who have invested years of effort in perfecting this aspect of barcode reader technology.

33. At the time of writing, the technological approach used by dPID is a significant departure from that of the major barcode reader manufacturers. Barcode reader manufacturers, for sound commercial reasons, have taken existing linear barcode reading technology and adapted it to being able to read 2D barcodes. In doing this they have resorted

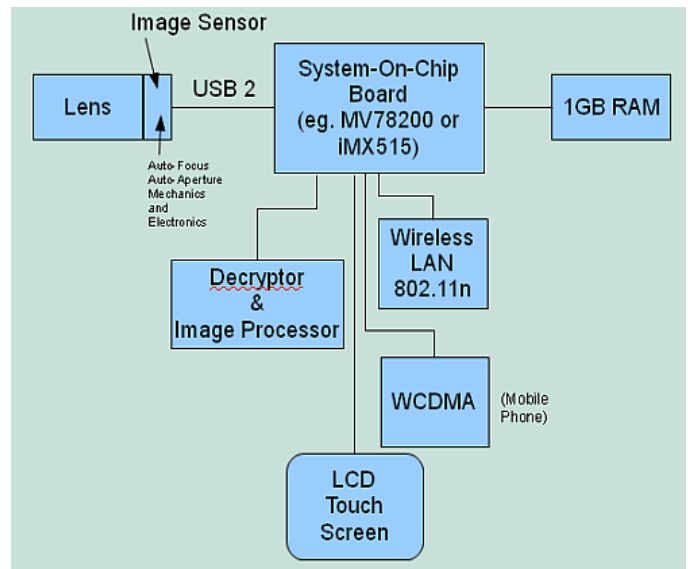

Figure 7. Block Diagram - Generic Reader

to commonly available general purpose processors executing object code, often compiled from source code written in the C programming language. This code executes in a serial fashion. Because of the limitations of this approach, it was necessary 2D barcodes carry unique markings to assist the barcode reader in its task of identifying, orientating and then reading a barcode in an acceptable timeframe.

34. The dPIID approach is different. It has been to invent a barcode design that is suitable for processing by algorithms embedded into silicon circuitry so that the reading process occurs in a much shorter time-period than is possible with software executing on a conventional processor. Because the whole process has been resolved down into silicon circuitry, it is possible to make thousands of similar processing circuits on the one chip, with all of these processes running in parallel; seeking out barcodes in a field of view, orientating them, reading them and decrypting the values to determine whether or not the Identifier read is valid. This approach heralds a new era in barcode readers where it possible to read many codes simultaneously at extreme speeds. Because of the power of this approach, it is not necessary for the barcode to have special markings to assist the reader to identify and orientate the barcode. This simplifies the barcode to simply being a collection of dots and this may be easily printed using a cheap printer or a laser etcher.

35. In order to prove this concept, dPIID has developed a circuit based upon a Field Programmable Gate Array (FPGA). Figure 8 shows a test bench for the purposes of using the FPGA to process the image of a 4.5 mm x 3.6 mm NU-ERA barcode, laser-etched into a small arms part provided by the Australian Defence Force. The etching has been filled with a UV fluorescent acrylic paint so that it only stands out when irradiated and so does not upset personal equipment camouflage. In its present form, the FPGA takes 26 seconds to read a barcode. dPIID is confident now that this can be reduced down to a three stage process with each stage taking around **5 milliseconds**. This means that the system has the ability to process **200 frames per second**. This is important because, given the level of magnification that is necessary to read the barcode, it is necessary there be a very fast frame rate in order to obtain a clear image if there is movement of the camera during the reading process. High frame rates also allow there to be a constantly varying focus system such that a few frames will be guaranteed to be in focus.

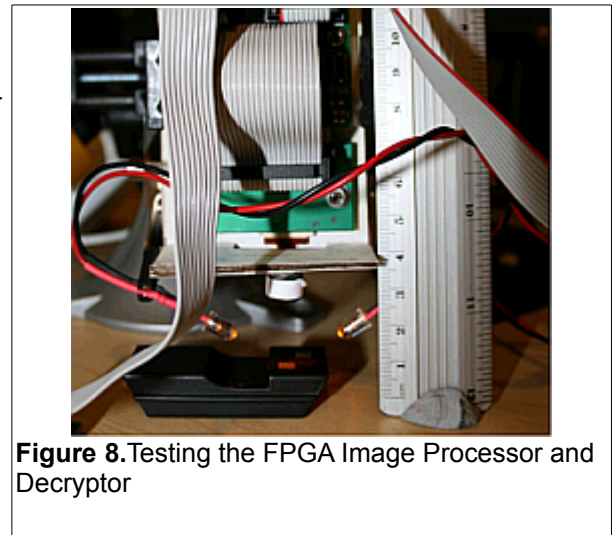

Figure 8. Testing the FPGA Image Processor and Decryptor

36. As a consequence of the research dPIID has successfully completed building a an FPGA device, it is confident there is no technological risk involved in now scaling this process and placing it into a silicon chip (referred to as an Application Specific Integrated Circuit – ASIC).

37. Once the silicon chip has been made, it can be used by every barcode reader, every camera and every mobile phone to read NU-ERA barcodes. Such devices would also be able to read a wide range of other barcode symbologies as well.

38. In order to rapidly detect a barcode in the field of view, dPIID has used a Centroid algorithm as displayed in Figure 9. Further processes rotate and scale the image and

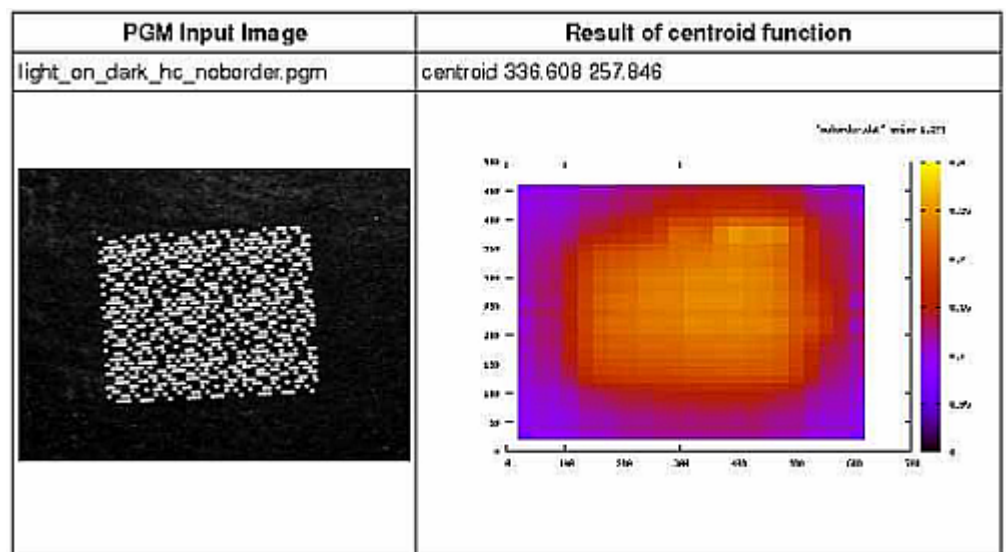

Figure 9. The Means of Rapidly Detecting a barcode in the Camera's Field of View

then read the barcode. Because the barcode consists of 9 identical arrays, the reader processing logic overlays each array in a virtual sense in order to determine whether a dot is real or dirt.



Figure 10. dPIId Prototype Reader using FPGA Hardware

39. Figure 10 displays the dPIId prototype reader to demonstrate the FPGA processing a dPIId NU-ERA barcode.

The Laser Etcher

40. Inexpensively printing a small unique pattern to very high resolution on every article passing down a production line poses a number of significant challenges for any form of conventional printing technology. Laser etching provides the means by which any object may be marked with dots but the equipment (as shown in Figure 11) capable of performing this is presently expensive (circa US \$70,000.00 at the time of writing).

41. Filling the dots with a fluorescent compound provides the means by which this pattern may be made to stand out and be better seen by image sensing technology. In the military context, the fluorescent paint is a dark green colour and so does not detract from the camouflage of the item or individual. When irradiated with UV light, it glows bright green and can be easily discerned and read. Laser

can also be used to remove a thin layer of ink on a wrapper or label, exposing an underlying fluorescent layer, or removing a fluorescent layer, such that a pattern of non-fluorescent dots are created.



Figure 11. Handheld Fiber-Laser Etching System used to Mark Weapons Parts

42. Figure 12 displays common 2D barcode symbologies, in use at the time of writing, that are capable of displaying dPID registry identifiers. Also displayed in this Figure 12 is a NU-ERA barcode, though, typically, the NU-ERA barcode is much smaller in size than the other symbologies. An important feature of the NU-ERA barcode is that it does not rely on fiducial marks to assist a reader to recognise and read it. Instead, as previously described, there is incorporated into the barcode a unique pattern that assists image processing logic to determine a barcode is within its camera's field of vision and then to orientate, scale and calculate the value represented by the barcode. The avoidance of the use of a fiducial mark, such as a square, a broad line or a circle, means that the NU-ERA barcode can be totally comprised of only dots. This feature was deliberately sought for the following reasons:

- a. It is easier for printing machinery to create a small dot than it is to create a square, a circle or a line. This allows NU-ERA tags to be made smaller than other common types of 2D barcode for any given type of printing technology applied.
- b. When laser etching the pattern onto an object's surface, a wrapper or a label, the etching laser can simply consist of an array of laser diodes or fibres rather than requiring the sophisticated system of lenses and motors presently necessary to generate the complex shapes that represent fiducial marks. The avoidance of this with NU-ERA technology means that much cruder, and hence cheaper, laser etching systems may be employed to create a NU-ERA 2D barcode.

43. Fibre laser technology is still relatively expensive. Laser diodes, because of their use in mass-produced items such as DVD writers, are not. In quantity laser diodes can be obtained for less than 50 cents US. An array of 36 laser diodes, necessary to print a row of dots of the NU-ERA barcode, would therefore cost around \$18 US. Pulse laser diode technology uses a semi-conductor wafer. If volumes of production justified it, it would be possible to have semi-conductor assembly emitting a row of laser beams. Conventional laser Diodes are not very powerful but they are powerful enough to remove a thin layer of ink on a food wrapper to expose another layer of ink underneath or raw plastic film. In either instance, this would be sufficient to create a NU-ERA barcode. Combined with the use of UV fluorescent inks, this would be a very effective way of identifying and individually accounting for every article on a supermarket shelf.

The Unique Identifier Registry (UNR)

44. dPID's model is to issue to client-systems large volumes of Identifiers⁴. The cost of an Identifier from dPID ranges between one tenth to one thousandth of a cent; depending on the volumes being purchased. For each purchase of Identifiers, no matter how many, there is a set administrative fee of \$10.00 only per purchase. **The power of the NU-ERA system is that it places within the reach of small business the ability to have every single item, no matter how trivial, individually identified by a unique Identifier without there being extraordinary accounting effort.** To do this, and to enable every business and commercial entity to interact with each other, the Identifiers must be guaranteed to be unique. That's where dPID's NU-ERA Identifier registry plays a role. The Identifier represented by a NU-ERA barcode is 96 bits long. The range of Identifiers in decimal terms is therefore between 0 and

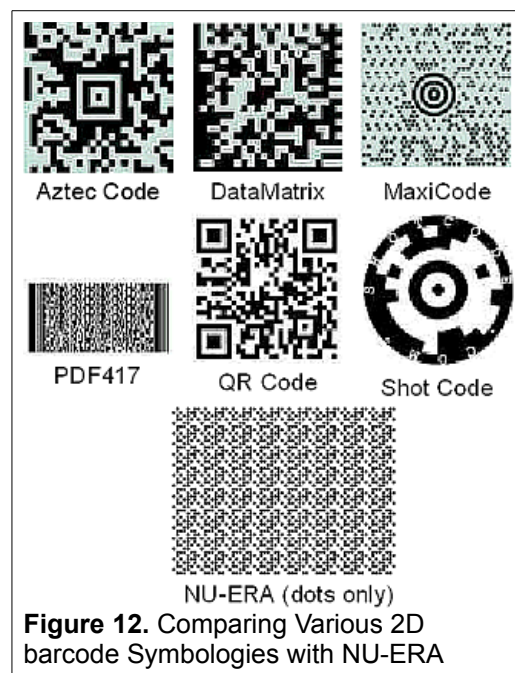

4 As an example, during the building of a demonstrator High Security Items system for BAE Systems Australia, nearly a quarter of a million Identifiers have been consumed in 6 months.

79,228,162,514,264,337,593,543,950,336. If the registry were to issue one thousand billion unique Identifiers per year, it would take more than 79 million billion years to exhaust these Identifiers.

45. The dPID NU-ERA UNR allocates Identifiers in a unique fashion. Rather than trying to divide up the Identifier domain into various segments according to application and customer, the dPID system is to issue a batch of Identifiers to a particular customer-system by starting in the middle of the largest existing expanse of Identifiers at the time the issue is made. This makes the dPID registry system significantly different to all other unique Identifier registry systems presently in operation and it is this system of Identifier allocation that makes the dPID registry so flexible and thus so useful to industry.

46. Figure 13 illustrates how this works. The very first issue of Identifiers is made by choosing the point halfway between 0 and 2^{96} . This is 2^{95} . The second allocation to a different Customer-System is made, commencing from the mid-point of the widest expanse of unallocated Identifiers, that is, 2^{94} . Likewise, the 3rd allocation to a different Customer-System starts from halfway between 2^{96} and the end of the first allocation which started from 2^{95} . And so we go to the 4th and 5th allocation. The 6th allocation however is from the same Customer-System as the 3rd allocation. In that case, the 6th allocation simply follows on from where the 3rd allocation left off. In this manner, every Customer-System is guaranteed of having a range of Identifiers that are always sequential. This simplifies things for customers and simplifies the administration of this system of allocation.

47. Another aspect of this registry is that the issued Identifiers, represented by the barcodes, are encrypted. In this manner it is not possible for someone to side-step the registry and invent new Identifiers. The allocated Identifiers are issued in pairs; one is the Identifier in clear, the other is the Identifier encrypted. Under present arrangements, where a commercial dPID reader is not available for reading and decrypting a NU-ERA barcode, another barcode symbology, such as DataMatrix or QRCode, may be used to represent the Identifier. If the user wishes to encrypt the Identifiers represented by the DataMatrix or QRCode, it is possible to use a decryption dongle developed by dPID. (See Figure 14) This decryption dongle takes a NU-ERA encrypted Identifier, represented by a conventional 2D barcode symbology such as DataMatrix and read by a conventional barcode reader, and decrypts it. It also performs a check on the Identifier to ensure it is valid. The chances of the

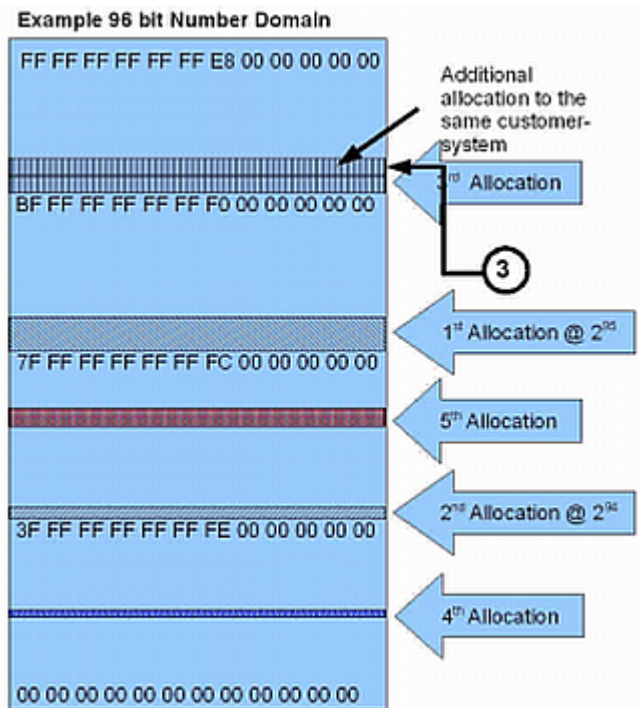

Figure 13. The Method Used to Allocate Identifiers from the dPID Unique Identifier Registry



Figure 14. Independent NU-ERA Decryption Option

Identifier being wrongly declared as being valid is around one in 4 trillion.

48. As previously mentioned, the encryption of the Identifiers, issued from the registry, prevents unauthorised persons or organisations generating NU-ERA ID Identifiers in competition with the registry. As described, the administration of the registry is such that there is no possibility of wastage of Identifiers and that every customer-systems' Identifier range will always be sequential, even when there are numerous issues of batches of Identifiers to any particular Customer-System over a long period of time. Customers are charged for the service of being issued a batch of Identifiers that are guaranteed to be unique, ie, not used by any other Customer-System.

- End of Paper -